

4" / 6" / 7" Yamaha Lift Kit

Fits Models: G-14, G-16, G-19, G-22

Note: This is a bolt-on lift kit. Offset wheels are recommended.

-REAR LIFT Instructions-

Raise cart & support frame w/ jack stands. Remove rear body inspection cover. Remove shocks from top mounts. Remove sway bar from bottom mount. Confirm that all wiring & cables are free of binding. Install new "H" bracket to upper shock mounts. Install shocks to "H" bracket. Shock mounts on front of axle bracket mount. Spacer bushings go inside lower shock axle mount bracket. Install new sway bar bracket and 3/8" aluminum spacer plate (see Diagram B) between axle and chassis with longer bolts. Replace fuel line or bend fuel pump bracket on gas models. Inner fender wells may need to be trimmed or tied back for tire clearance on some tire sizes.



(Diagram A - Rear View)

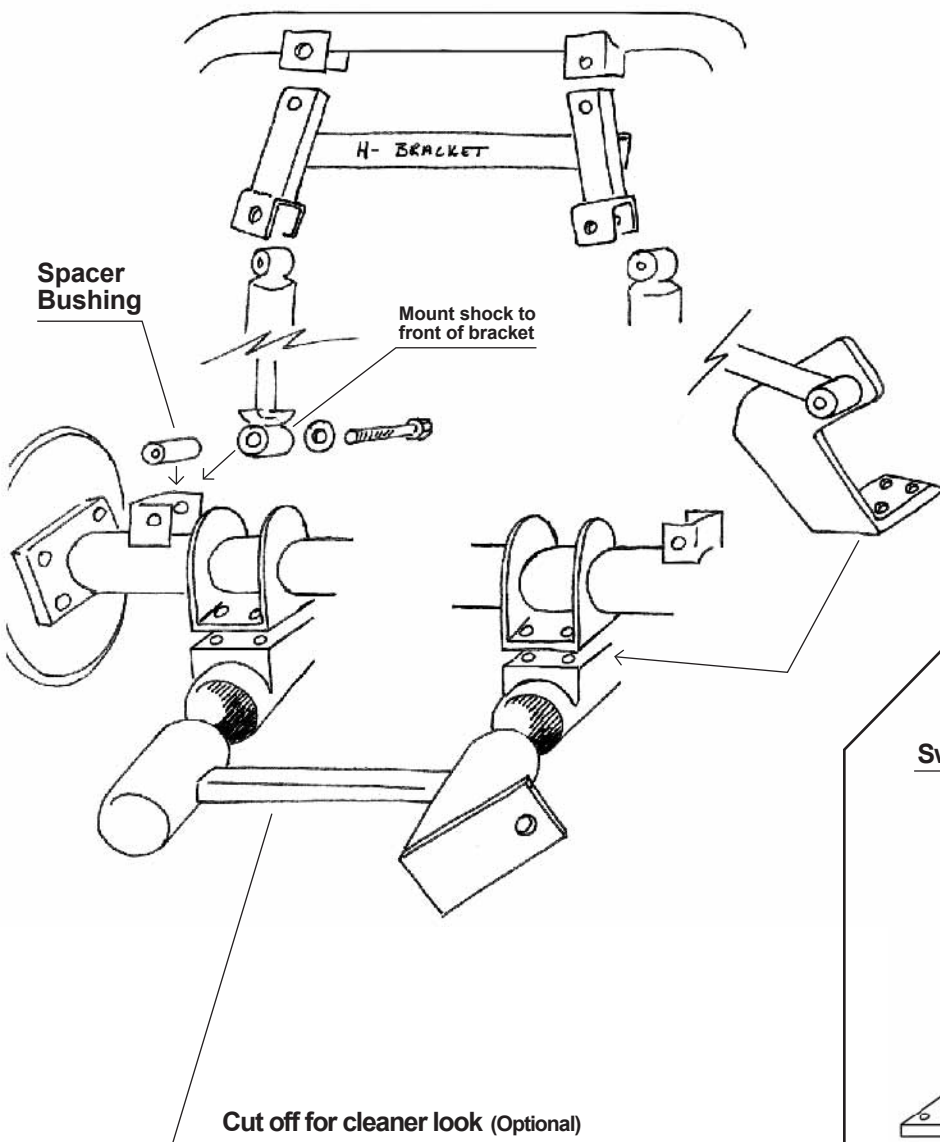

(Diagram B - Rear View)

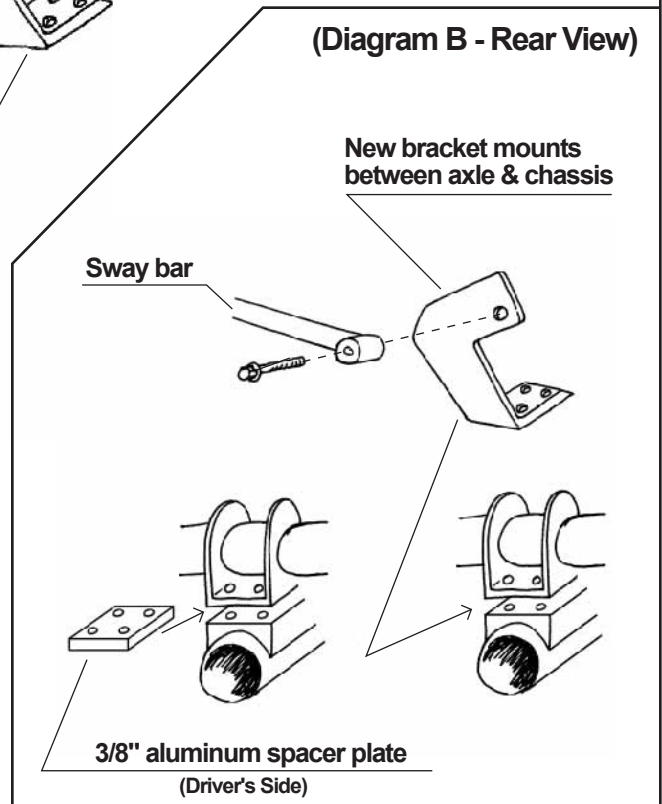

DISCLAIMER: All lift kit or accessory installations should only be performed by professional mechanics. The lift kit buyer assumes sole responsibility for, and shall indemnify the dealer/retailer, from any and all liability, claim, responsibility, and damage, or any costs or expenses resulting from any loss of life or injuries or claimed injuries to persons or property that may be sustained in connection with the use of any product before or after purchase, including but not limited to lift kits. Dealer/retailer reserves the right, at any time, to discontinue or change prices, specifications, features, designs, models or equipment without further notice and without incurring any further obligations.