

6" Club Car A-Arm Lift Kit

Fits Years 1993 - 2005

This is a bolt-on lift kit. Offset wheels are recommended.

-FRONT LIFT Instructions-

Remove and discard spindles, spring & large steel plate. Remove shocks, unbolt A-Arm (delta plate) & flip upside down. Shock mounting bolt should now be facing towards floor pan. Use (4) aluminum 3/8" spacers, bolts & nuts to space A-Arm forward when bolting A-Arm on to align with spring. Mount shock on back of bracket, use bushing inside. Mount new aluminum spring plate with spring slot on bottom side (use original eccentric bolt from old spring). Mount new spring with lower A-Arm assembly plate. Now A-Arm and spring should be aligned to mount spindle. Leave camber bracket & spring loose. Use original hubs & bearings. (properly greased). Leave camber adjustment bolts loose at spring ends.

Now you are ready for adjustments:

Mount tires. Lower cart to the ground. Adjust camber using 2" square on side of tire to floor. 1/4" gap in at bottom. This is done by sliding camber bracket, at lower A-Arm, in & out then tighten. Adjust toe in 1/8" (Use straight edge on side of tires, measure back & then adjust 1/8" in on front. Adjust center eccentric bolt inspring for even side to side if necessary.

Note: Drive cart around then check adjustments. Repeat adjustments if necessary.

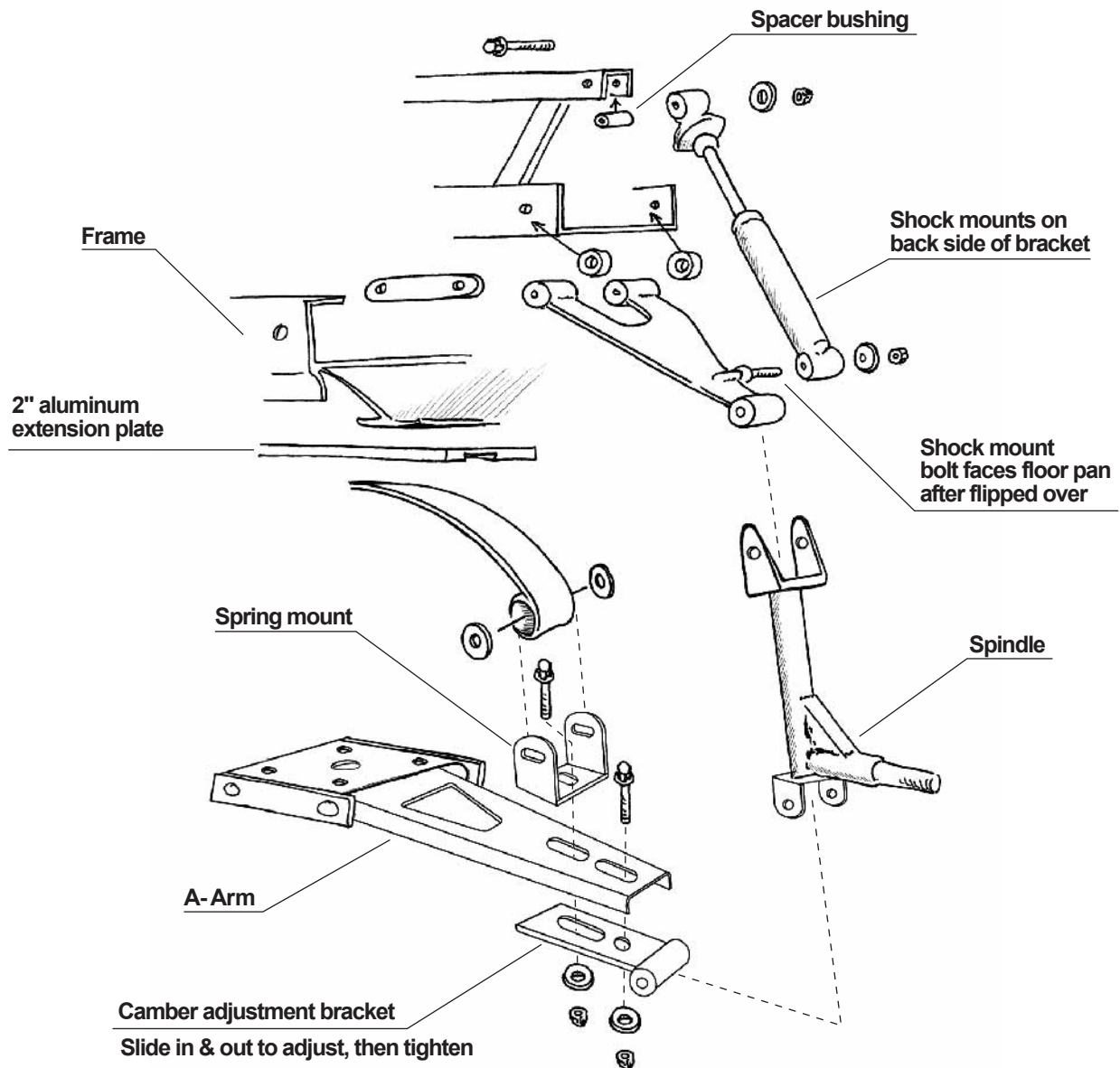
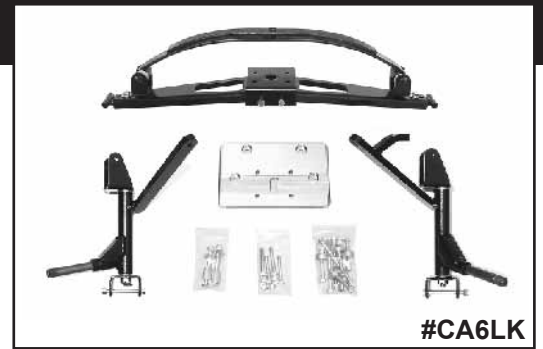

DISCLAIMER: All lift kit or accessory installations should only be performed by professional mechanics. The lift kit buyer assumes sole responsibility for, and shall indemnify the dealer/retailer, from any and all liability, claim, responsibility, and damage, or any costs or expenses resulting from any loss of life or injuries or claimed injuries to persons or property that may be sustained in connection with the use of any product before or after purchase, including but not limited to lift kits. Dealer/retailer reserves the right, at any time, to discontinue or change prices, specifications, features, designs, models or equipment without further notice and without incurring any further obligations.