

4"/ 7"/ 9" Club Car Z-Bracket Lift Kit

Fits Years 1984-2003

NOTE: This kit requires welding & cutting. Offset wheels recommended.

-FRONT LIFT Instructions-

Raise cart on jack stand under front frame. Remove front bumper, suspension, separate steering universal in middle. Measure from front chassis back 16". Mark top and both sides of frame using a Z-bracket plate for proper angle.

Cut both sides of frame along marks. Slip Z-bracket into frame. Drill center hole first in each 3 hole plate and bolt on to frame. This will hold bracket tight to frame so you can easily drill other 2 holes. Reassemble suspension on to frame.

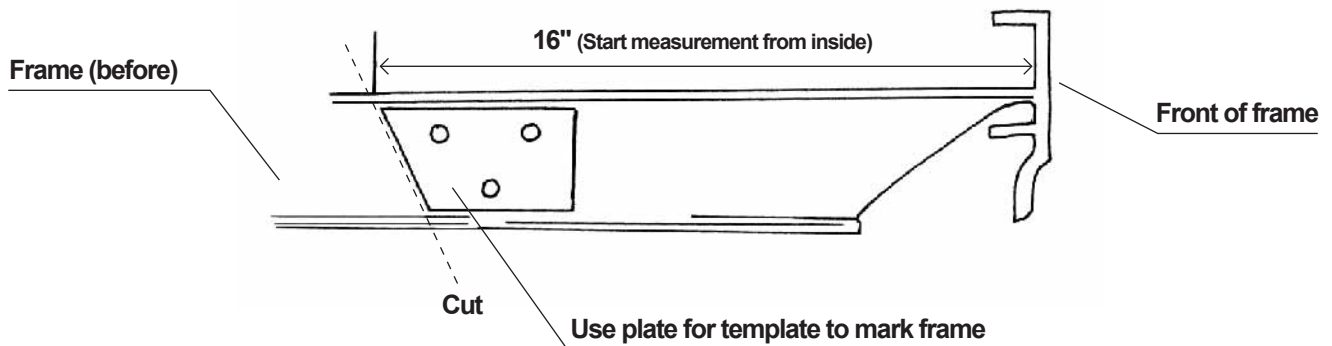

Slip steering extension pipe over spline & butt end to end. Tack weld 3 spots. Rotate steering to make sure there is no binding then weld fast. Wrap universal area w/ wet towel to cool down sealed area.

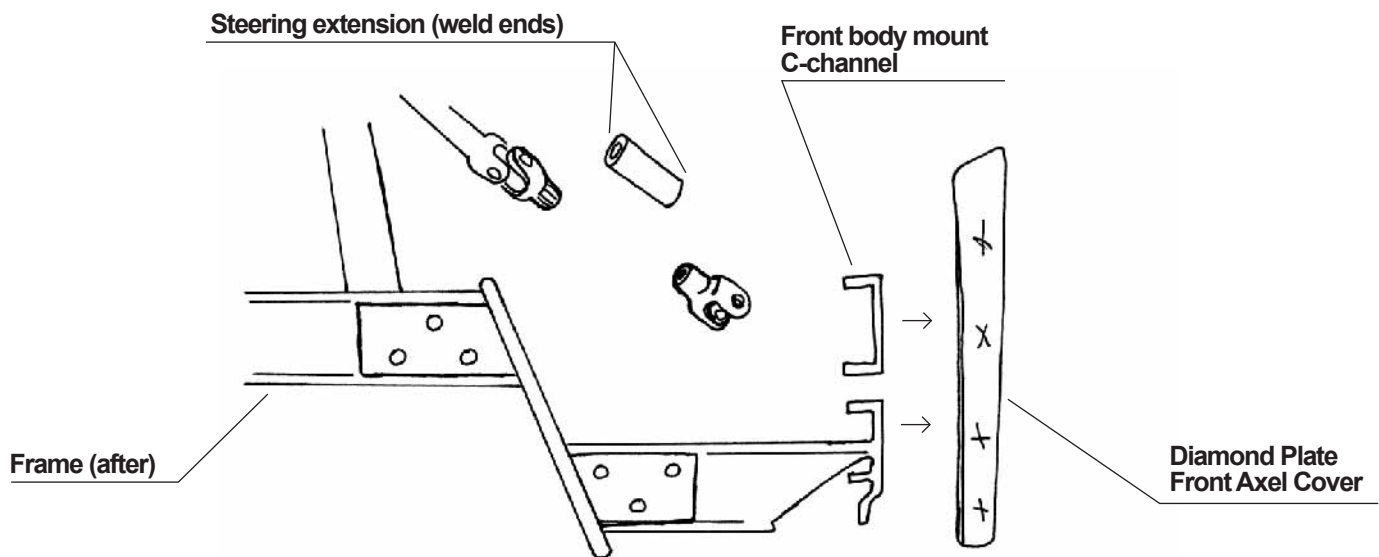

Bolt front body to C-channel - Float diamond plate, drill and bolt to center of C-channel and bumper.